

2 SQUARE PLATE ELECTRIC HOB ON OPEN BASE CABINET



- External paneling in stainless steel
- Electric cooktop in AISI 304 stainless steel
- Moulded work surface in AISI 304, 1.2 mm thick, with raised edges to prevent spills.
- Height-adjustable work surface from 855 to 900 mm
- Square hot plates, 220x220 mm, in cast iron
- No. 2 hot plates, each 2.6kW, hermetically sealed to the work surface
- Heating regulation via 6-position selector
- Ergonomic control panel with controls tilted toward the operator
- Hot plates equipped with automatic reset safety thermostat, which activates in case of use without pans or with unsuitable pans
- Indicator lights to monitor the correct operation of the appliance
- Height-adjustable stainless steel feet

TECHNICAL SPECIFICATIONS

| | |
|--------------------------|-------------|
| Dimensions (mm) | 400x700x900 |
| Volume (m ³) | 0,60 |
| Weight (kg) | 60 |

ELECTRICAL CONNECTION

| | |
|------------------|-----------------------|
| kW | 5,2 |
| Power supply | VAC 400/3N 50/60Hz |
| Cold water inlet | |

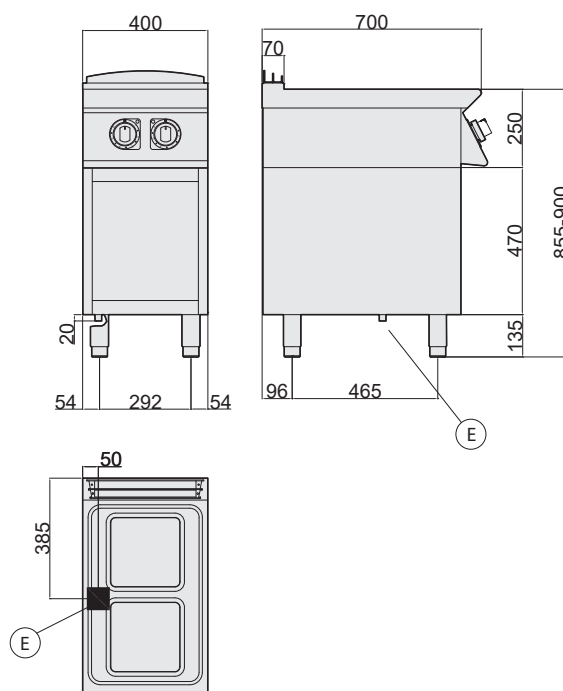

- Ⓐ water fill
- Ⓒ hot water fill
- Ⓔ electrical input
- Ⓕ cold water fill
- Ⓖ gas inlet
- Ⓗ water drain

