

### 4 ROUND PLATE ELECTRIC HOB ON ELECTRIC OVEN



- External paneling in stainless steel
- Electric cooktop in AISI 304 stainless steel
- Moulded work surface in AISI 304, 1.2 mm thick, with raised edges to prevent spills.
- Height-adjustable work surface from 855 to 900 mm
- Circular hot plates Ø 220 mm, in cast iron
- No. 4 hot plates, each 2.6kW, hermetically sealed to the work surface
- Heating regulation via 6-position selector
- Ergonomic control panel with controls tilted toward the operator
- Hot plates equipped with automatic reset safety thermostat, which activates in case of use without pans or with unsuitable pans
- Electric oven base in steel
- Standard electric oven, 6.2 kW power
- Heating with independently regulated top and bottom heating elements
- Thermostat for temperature regulation between 50°C and 300°C
- 4-position switch and safety thermostat
- Cooking chamber dimensions, 693x300Hx580 mm GN 2/1
- Moulded inner door
- Indicator lights to monitor the correct operation of the appliance
- Height-adjustable stainless steel feet

#### TECHNICAL SPECIFICATIONS

Dimensions (mm)	800x700x900
Volume (m <sup>3</sup> )	0,90
Weight (kg)	130

#### ELECTRICAL CONNECTION

kW	16,6
Power supply	VAC 400/3N 50/60Hz
Cold water inlet	

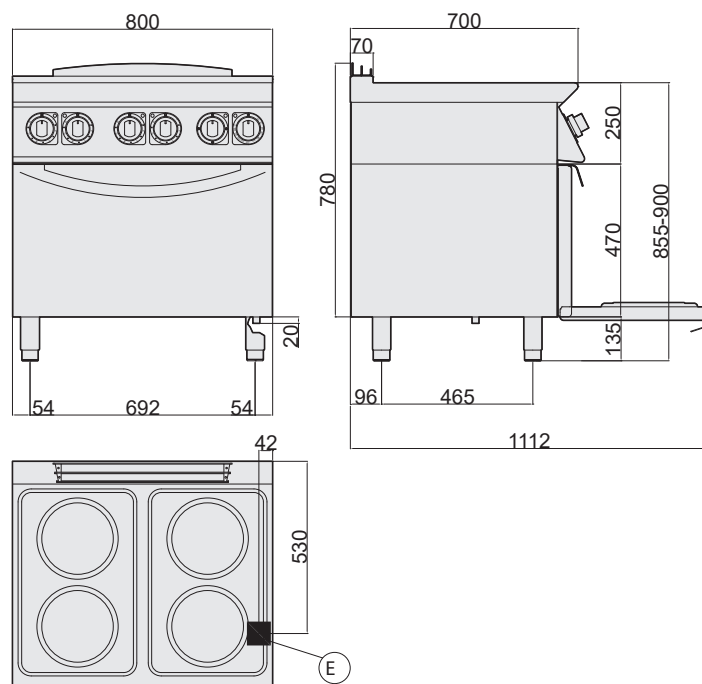

- Ⓐ water fill
- Ⓒ hot water fill
- Ⓔ electrical input
- Ⓕ cold water fill
- Ⓖ gas inlet
- Ⓗ water drain

