

ETE5

Combi Electric Oven - 5 GN 1/1_5GN 60x40



TECHNICAL FEATURES

- Heating of cooking chamber with high performance INCOLOY heating elements.
- Adjustable fan speed in 3 position.
- Double-glazed ventilated door (panels can be opened for easy cleaning).
- AISI 304 cooking chamber with rounded corners.
- Height adjustable feet.
- USB port for uploading and saving recipes and for firmware updating.
- Motorised vent valve opening
- Single control by means of just one jog/dial encoder knob.

OPTIONS:

- ETE5W Washing system included
- Optional rack for 60x40 trays.

USER INTERFACE:

TOUCH SCREEN PANEL 5"

Convection, steam, convection with steam in combi mode, humidification and dehumidification, cook with core probe, hold in temperature for overnight cooking.

These are the Easyair's functions, an oven line which is suitable to take either gastronorm and confectionery size trays and containers.

RecipeTuner

The RecipeTuner interface makes it possible to modify and personalise the various programs simply and intuitively. RecipeTuner changes according to the type of cooking set, to regulate cooking, browning, degree of humidity and of leavening.

EasyService

level control cooking

The new Rack Control enables different dishes to be cooked at the same time at various levels. What's more, with EasyService, a new Rack Control function, all the dishes can be served at the same time.

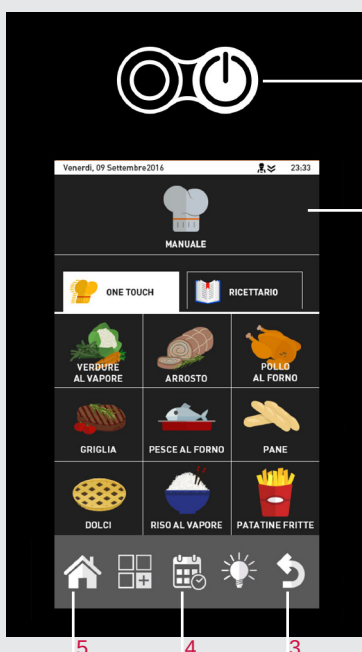

1. On/Off switch.

2. Touch Screen Panel.

- Temperature control from 50° to 300°C
- Time control from 1' to 120'; infinite function.
- Cooking modes: convection, steam, combi convection/steam.
- "One Touch" cooking mode: immediate start of the cooking cycle with "one touch programs".
- Preset cooking programmes. Possibility of controlling 9 cooking phases for each programme.
- Cooking with "Rack Control"
- Interface "Recipe Tuner"
- Delta T cooking.
- Cooking with probe.
- Multi level cooking with "Easy service"
- Hold function.
- Cooldown during cooking.

3. Back Key

4. "Scheduled Departure" key.

5. Main Menu key.

ETE5

Combi Electric Oven - 5 GN 1/1_5GN 60x40

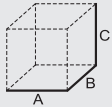
 (A x B x C) mm	VOL./PESO Vol./Weight m ³ /kg	VAC 400V-3N 50Hz (60 Hz optional) kW	POTENZA EL. CAMERA Oven cavity el. power kW	DISTANZA TRA LE TEGLIE Distance between the layers mm	DIM. CAMERA Cavity net dimension mm
870x749x663 5 GN 1/1 5 EN 60x40	0,39 / 65	6,3	6	74	645x420x450

ACCESSORIES

- Stand TSP0500
- Racks for stand TSP0500 cod. 2017691
- Proofer CLP0810
- Proofer CL900
- Proofer CL912
- Hood 7080516
- Condensation hood 7080522
- Core probe 6000116
- Probe for sous-vide cooking 6000117
- Hand spray 7080003
- Stacking kit on demand

ACCESSORIES FOR PATISSERIE USE

- 2023826 racks 60x40 size 80.
- 2024356 racks 60x40 size 90

- A Electrical connection
- B Water inlet (G3/4)
- C Drain connection (Ø32)

WATER QUALITY REQUIREMENTS

Hardness	60-100 ppm
TDS	<100 mg/L
PH Value	7.0-8.0
Cl ₂ Free chlorine.....	<0,5 mg/L
Cl Chloride.....	<20 mg/L
Alkalinity.....	<20 mg/L
SiO ₂ Silica.....	<10 mg/L

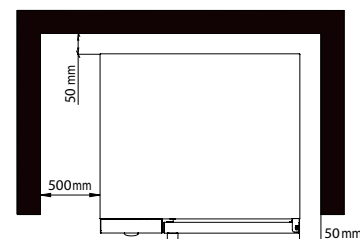
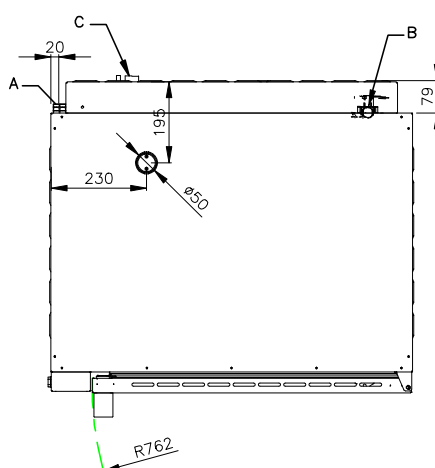
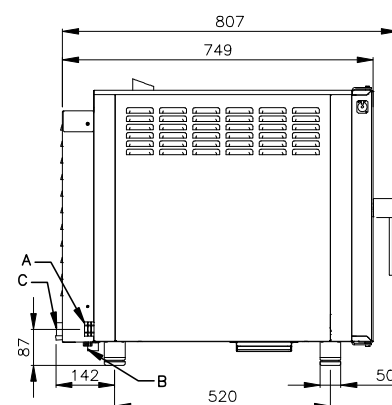
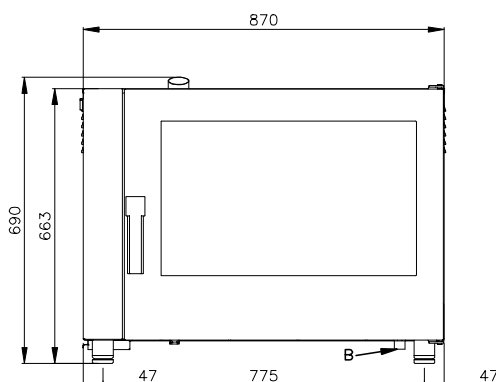

* Clearance requirements

NOTE

* Drain line must be vented