

# FD/HD 415











THREE PHASE  
400 V / 50 Hz

## MODULAR ICE CUBE MACHINE

### FEATURES CARACTERÍSTICAS

- ▶ **PRODUCES FULL DICE ICE CUBES OR HALF DICE ICE CUBES**  
PRODUCE CUBITOS DE DADO Y MEDIO DADO
- ▶ **HIGH EFFICIENT EVAPORATOR**  
EVAPORADOR DE ALTA EFICIENCIA
- ▶ **SMART WATER DISTRIBUTOR THAT IMPROVES DROP-OFF EFFICIENCY**  
DISTRIBUIDOR DE AGUA INTELIGENTE QUE MEJORA LA EFICIENCIA EN EL DESPEGUE
- ▶ **EASY ACCESS BY REMOVING THE PANELS WITH A SINGLE SCREWDRIVER**  
FÁCIL ACCESO RETIRANDO LOS PANELES CON UN SOLO DESTORNILLADOR
- ▶ **SMART ELECTRONIC BOARD CONTROLS EVERY PARAMETER IN THE MACHINE AND SHOWS THE DIAGNOSIS OF POSSIBLE INCIDENCES**  
PLACA ELECTRÓNICA INTELIGENTE QUE CONTROLA LOS PARÁMETROS DE LA MÁQUINA Y MUESTRA EL DIAGNÓSTICO DE POSIBLES INCIDENCIAS
- ▶ **ENERGY STAR, LOW POWER CONSUMPTION CERTIFICATION**  
ENERGY STAR, CERTIFICADO DE BAJO CONSUMO ELÉCTRICO
- ▶ **HIGH RESISTANCE EXTERNAL FRAME IN AISI 304 STAINLESS STEEL**  
ESTRUCTURA DE ALTA RESISTENCIA EN ACERO INOXIDABLE AISI 304



	 24 H	 10°C	 10°C	 21°C	 15°C	 (mm)	 (mm)	 <b>FD/HD 6'5cc</b> 23 mm (W) x 11 mm (D) x 26 mm (H) Average dimensions Dimensiones promedio	
FD/HD 415 A		424	405	Width 762	Depth 620	Height 760	Width 836	Depth 635	Height 874
FD/HD 415 W		436	416	Width 762	Depth 620	Height 760	Width 836	Depth 635	Height 874

### ACCESSORIES ACCESORIOS

#### INCLUDED



**WATER INLET FILTER GASKET**  
JUNTA DE FILTRO DE ENTRADA DE AGUA



**WATER INLET HOSE**  
MANGUERA DE ENTRADA DE AGUA



**WATER OUTLET HOSE**  
MANGUERA DE DESAGÜE

#### NOT INCLUDED (OPTIONAL)



**ANTI-LIMESCALE FILTER**  
FILTRO ANTICAL



**PARTICLE FILTER**  
FILTRO ANTIPARTÍCULAS



**ANTI-LIMESCALE + ANTI-CHLORINE FILTER CS101**  
FILTRO ANTICAL + ANTICLORO CS101

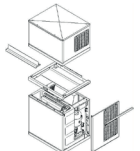

**STACKING KIT**  
KIT APILADO

### RECOMMENDED BINS SILOS RECOMENDADOS

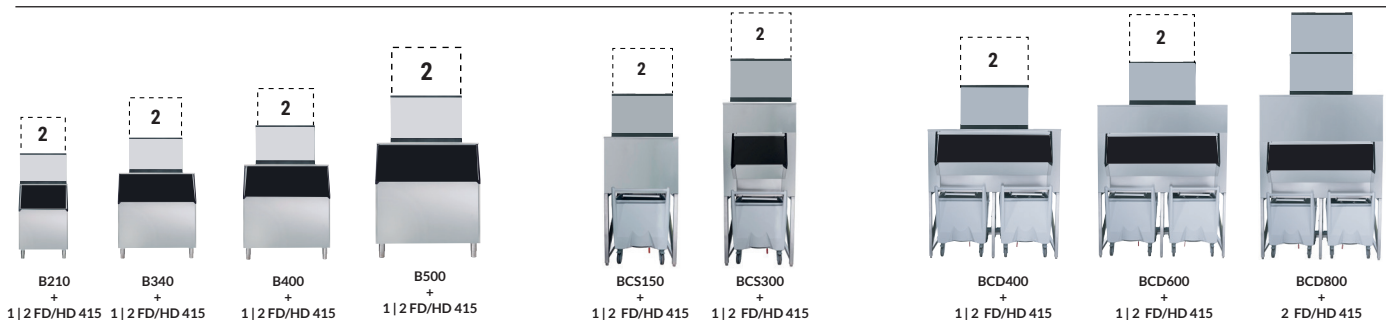

RIGHT SIDE VIEW  
VISTA LATERAL DERECHA

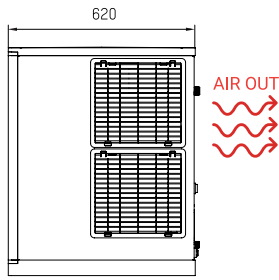

FRONTAL VIEW  
VISTA FRONTAL

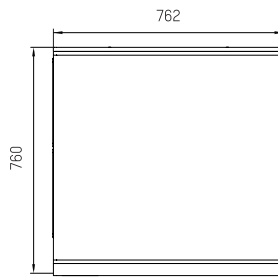

REAR VIEW  
VISTA TRASERA

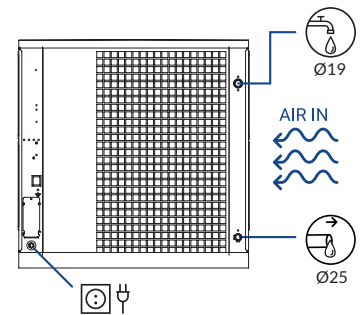

CENTRAL CROSS SECTION VIEW OF THE  
BASE  
VISTA DE LA BASE DESDE SECCIÓN  
CENTRAL

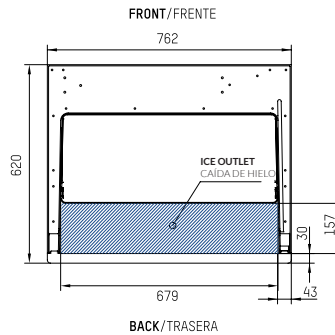

\* All measurements in mm.  
\* Todas las cotas en mm.

OPERATING CONDITIONS CONDICIONES DE OPERACIÓN

PRODUCTION 50Hz PRODUCCIÓN 50 Hz

±10% V

5°C/43°C

5°C/35°C

1 bar/6 bar

400/800 Ice cubes/cycle

V	Hz	ph
400	50	3N



FD/HD 415 AIR COOLED

°C / °F	10° / 50°	15° / 60°	21° / 70°	30° / 86°
10° / 50°	424	412	395	379
21° / 68°	413	405	386	368
32° / 90°	359	333	301	284
43° / 109°	293	259	232	217

FD/HD 415 WATER COOLED

°C / °F	10° / 50°	15° / 60°	21° / 70°	30° / 86°
10° / 50°	436	423	406	389
21° / 68°	425	416	397	378
32° / 90°	369	342	310	291
43° / 109°	301	266	239	223

MODELS  
MODELOS

FD/HD 415 A

FD/HD 415 W

	ASHRAE CONDITIONS CONDICIONES ASHRAE	(W)	(BTu/h)	(W) 43°C	(n.)	(mm <sup>2</sup> )	FUSE	100 Kg (Kwh)	(l/h) FULL   HALF	HEAT REJECTED (W)	(BTu/h)	(Kg)	(Kg)	(m <sup>3</sup> )
FD/HD 415 A		11.185	38.185	1.540	3	2,5	15	9,9	17   17	3.505	11.960	105	110	0,53
FD/HD 415 W		11.185	38.185	1.540	3	2,5	10	9,9	110   110	3.505	11.960	105	110	0,53