

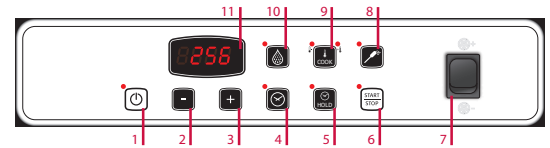

# GR0711E

## HOLDING-REGENERATING OVEN 7 (1/1 GN-600x400) ELECTRONIC VERSION

- Oven chamber heating by means of high-performance INCOLOY heating elements.
- Aisi 304 oven chamber with rounded corners.
- Reversing motor rotation for even cooking.
- Height-adjustable feet.
- 2 speed fan.
- 10 programs set with 2 cooking steps.
- Automatic preheating.
- Core probe.



- 1 On/Off switsch.
- 2 Increase
- 3 Decrease
- 4 Timer
- 5 Hold function
- 6 Start/stop cycle
- 7 Select speed
- 8 Core-probe function
- 9 Set regenerating temperature
- 10 Humidifier
- 11 Display

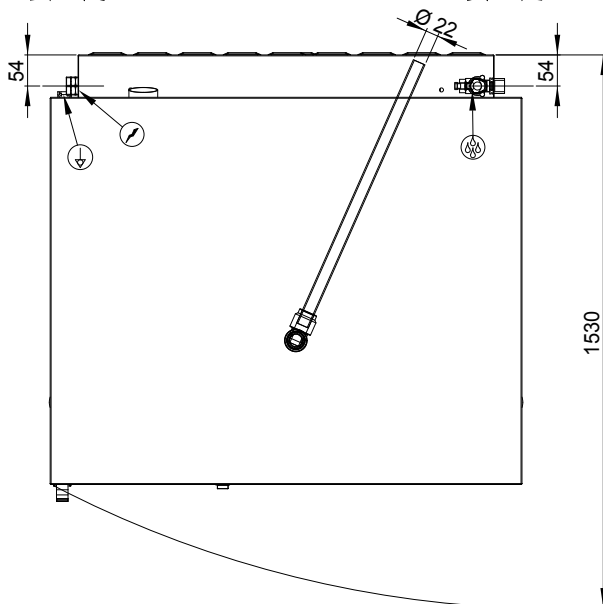
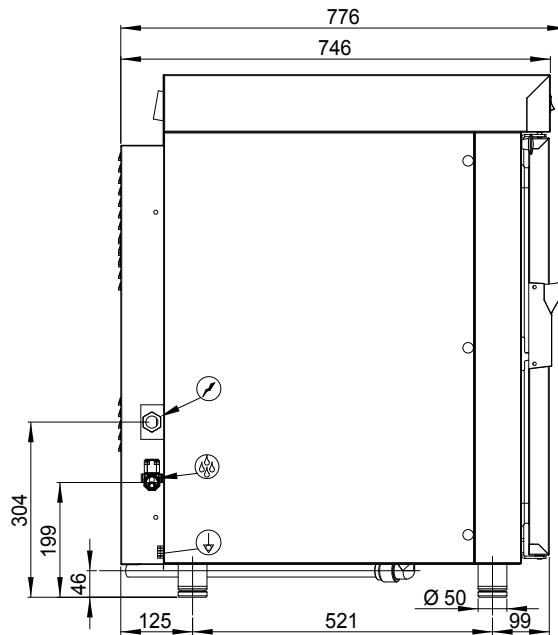
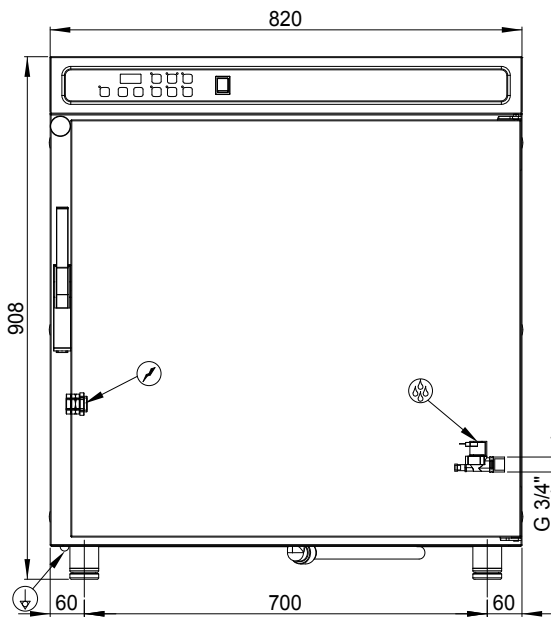

### TECHINICAL DATA

Dimensions: **820x746x908 mm**

Volume: **0,55 m<sup>3</sup>**

Weight: **80 Kg**

Chamber capacity: **7x(1/1 GN-600x400)**

Distance between layers: **74 mm**

Net dimension of oven cavity: **645x600x450 mm (LxHxP)**

Oven cavity power: **9 kW**

Total electric power: **9,6 kW**

Power supply voltage: **3N 400V AC-50Hz**