



GR F 310

230 V / 50 Hz











MODULAR FLAKE ICE MACHINE

FEATURES CARACTERÍSTICAS

- ▶ **PRODUCES COMPACT GRANULAR ICE**
PRODUCE HIELO GRANULAR COMPACTO
- ▶ **HIGH EVAPORATOR EFFICIENCY: LOWER ENERGY CONSUMPTION AND HIGHER ICE PRODUCTION**
EVAPORADOR DE ALTA EFICIENCIA: MENOR GASTO ENERGÉTICO, MAYOR PRODUCCIÓN DE HIELO
- ▶ **EVAPORATOR WITHOUT GASKETS OR SEALS**
EVAPORADOR SIN JUNTAS DE ESTANQUEIDAD NI RETENES
- ▶ **STAINLESS STEEL AUGER WITH RESILIENT COATING TO MAXIMIZE LIFESPAN**
HUSILLO DE ACERO INOXIDABLE CON POSTERIOR TRATAMIENTO SUPERFICIAL PARA AUMENTAR SU VIDA ÚTIL
- ▶ **POWERFUL SPEED REDUCER ON TOP**
POTENTE REDUCTOR DE VELOCIDAD EN LA PARTE SUPERIOR
- ▶ **AISI 304 STAINLESS STEEL BODY**
CÁRROCERÍA EN ACERO INOXIDABLE AISI 304
- ▶ **ELECTROMECHANICAL CONTROL SYSTEM**
SISTEMA ELECTROMECÁNICO DE CONTROL
- ▶ **ICE DROPS OUT THROUGH THE OPENING ON THE BOTTOM OF THE UNIT**
EL HIELO SALE POR UNA ABERTURA EN LA PARTE INFERIOR DE LA UNIDAD
- ▶ **ON/OFF LIGHTED ROCKER SWITCH IN FRONT PANEL**
INTERRUPTOR LUMINOSO DE FUNCIONAMIENTO ON/OFF EN EL PANEL FRONTAL
- ▶ **TROPICALIZED MACHINES (T CLASS)**
MÁQUINAS TROPICALIZADAS (CLASE T)



THE INSTALLATION OF AN ANTI-SCALE FILTER AND PERIODIC CLEANING ARE ADVISED IN AREAS WITH MEDIUM OR HIGH LIMESCALE CONTENT (HARD WATER)
SE ACONSEJA LA INSTALACIÓN DE UN FILTRO ANTICAL Y LIMPIEZA PERIÓDICA EN CASO DE AGUAS CON CONTENIDO EN CAL MEDIO O ALTO (AGUAS DURAS)

	24 H 	10°C 	10°C 	21°C 	15°C 			
	(Kg)	(Kg)	(Kg)	(Kg)	(Kg)	(mm)	(mm)	COMPACT GRANULAR ICE 25% RESIDUAL WATER CONTENT
GR F 310 A		-	325	Width 559 Depth 622 Height 712	Width 636 Depth 695 Height 835			
GR F 310 W		-	-					

ACCESSORIES ACCESORIOS

INCLUDED



WATER INLET FILTER GASKET
JUNTA DE FILTRO DE ENTRADA DE AGUA



WATER INLET HOSE
MANGUERA DE ENTRADA DE AGUA



WATER OUTLET HOSE
MANGUERA DE DESAGÜE

NOT INCLUDED (OPTIONAL)



LARGE SCOOP
PALA GRANDE



ICE DELIVERY CHUTE
TUBO CAÍDA DE HIELO



DISPERSION CONE
CONO DE DISPERSIÓN



ANTI-LIMESCALE FILTER
FILTRO ANTICAL



PARTICLE FILTER
FILTRO ANTIPARTÍCULAS



EXTERNAL STOP FULL BIN PHOTO CELL
SENSOR DE PARO EXTERNO POR LLENADO

RECOMMENDED BINS SILOS RECOMENDADOS



B175 + GR N 300



B210 + GR N 300



B340 + GR N 300



B400 + GR N 300



B500 + GR N 300



BCS150 + GR N 300



BCS300 + GR N 300



BCD400 + GR N 300



BCD600 + GR N 300



BCD800 + GR N 300

TECHNICAL SCHEME ESQUEMA TÉCNICO

GR F 310

RIGHT SIDE VIEW
VISTA LATERAL DERECHA

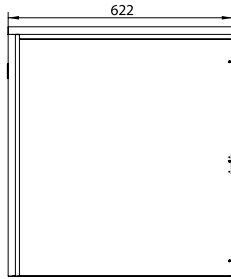

FRONTAL VIEW
VISTA FRONTAL

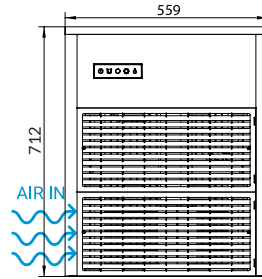

REAR VIEW
VISTA TRASERA

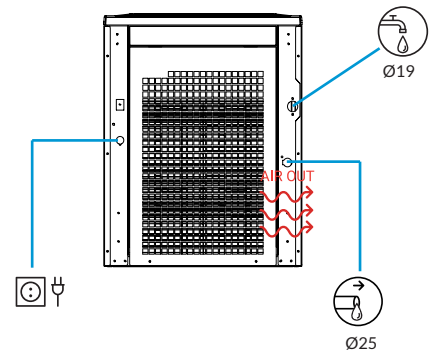

CENTRAL CROSS SECTION
VIEW OF THE BASE
VISTA DE LA BASE DESDE
SECCIÓN CENTRAL

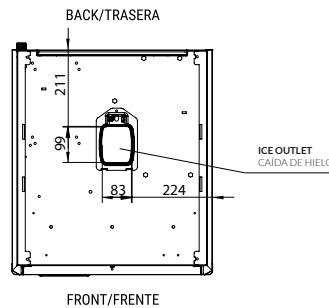

* All measurements in mm.
* Todas las cotas en mm.

OPERATING CONDITIONS CONDICIONES DE TRABAJO

PRODUCTION 50Hz PRODUCCIÓN 50 Hz

±10% V

10°C/43°C

5°C/38°C

1 bar/6 bar

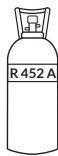

V	Hz	ph
230	50	1N

GR F 310 AIR COOLED

°C	10°	15°	21°	30°
°F	50°	60°	70°	86°
10°	-	-	-	-
50°	-	-	-	-
21°	-	325	-	-
68°	-	-	-	-
32°	-	-	-	-
90°	-	-	-	-
43°	-	-	-	-
109°	-	-	-	-

GR F 310 WATER COOLED

°C	10°	15°	21°	30°
°F	50°	60°	70°	86°
10°	-	-	-	-
50°	-	-	-	-
21°	-	-	-	-
68°	-	-	-	-
32°	-	-	-	-
90°	-	-	-	-
43°	-	-	-	-
109°	-	-	-	-

MODELS
MODELOS



Temp. Ev.
(°C)

ASHRAE CONDITIONS
CONDICIONES ASHRAE
(W) (BTU/h)

(W)
43°C

(n.)
(mm²)

FUSE

100 Kg
(Kwh)

(l/h)

HEAT REJECTED
(W) (BTU/h)

(Kg)

(Kg)

(m³)

GR F 310 A



-15°

3.355 11.448

1.360

3 1,5

10

8,6

13,5

2.214 7.554

84

93

0,38

GR F 310 W



-

-

-

-

-

-

-

-

-

-

-

