



KORE "B" offers two methods of generating steam: boiler-generated and instant mode. With the Symbiotic System it's possible to gain the maximum advantage from the two individual systems and overcome their limitations. These advantages are easy to measure in terms of speed, efficiency, energy-saving and steam quality.

steam tuner

Steambox is fitted with a patented system that makes it possible to adjust the moisture level in the steam, setting this to the right degree of dryness or wetness that the cooking method requires.

Meteo SYSTEM

To guarantee a perfectly balanced climate inside the cooking chamber, Giorik has patented a unique humidity control system (Meteo System) using software that analyses the relevant parameters in the cooking chamber and then regulates the production of steam or discharges excess humidity.

RecipeTuner

The RecipeTuner interface makes it possible to modify and personalise the various programs simply and intuitively. RecipeTuner changes according to the type of cooking set, to regulate cooking, browning, degree of humidity and of leavening.

EasyService

level control cooking

The new Rack Control enables different dishes to be cooked at the same time at various levels. What's more, with EasyService, a new Rack Control function, all the dishes can be served at the same time.

TECHNICAL FEATURES

- Heating of cooking chamber with PREMIX GAS BURNERS.
- Rapid chamber ventilation system.
- Meteo system (patented) for humidity control in the cooking chamber.
- Inverter-controlled fan with 6 different speeds.
- Immediate shutdown of the fan rotation by opening the door.
- Steam production with Symbiotic System (patented).
- High efficiency boiler with automatic descaling
- Steam tuner (patented) for tuning dry-wet steam.
- USB port for uploading and saving recipes and for firmware updating.
- Double-glazed ventilated door (panels can be opened for easy cleaning).
- Cooking chamber lighting with LED.
- Height adjustable feet.
- Single control by means of just one jog/dial encoder knob.
- Motorised vent valve opening.

STANDARD EQUIPMENT:

- Core Probe 6000124
- Automatic washing system (tabs or liquid) - n.4 programs

OPTIONS:

- Left hinged door (on request)

USER INTERFACE:

TOUCH SCREEN PANEL 7"

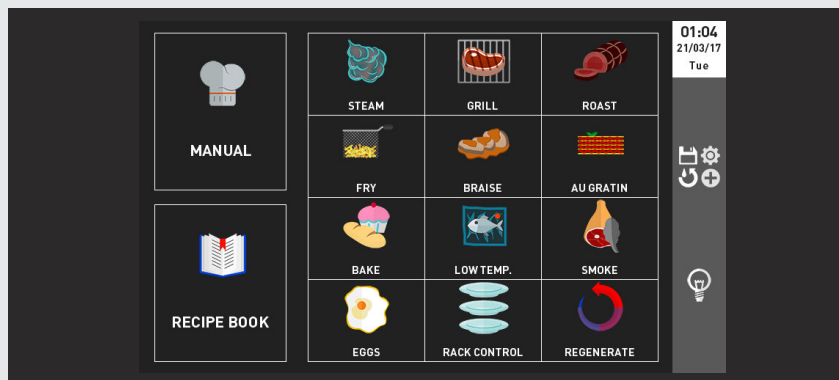

- Temperature control from 30° to 300°C.
- Time control from 1'to599'; infinite function.
- Cooking modes: convection, steam, combi convection/steam.
- Preset cooking programmes. Possibility of controlling 9 cooking phases for each programme.
- Delta T cooking.
- Cooking with probe.
- Multi level cooking with "Rack Control & Easy service".
- Recipe Tuner
- Cooking chamber humidity control (Meteo system).
- Steam tuner: dry-wet steam.
- Cooldown during cooking.
- Cook and hold function
- Regeneration function
- Dedicated Hot/Cold Smoking programs
- Cooking by Message
- Overnight cooking
- Delayed start

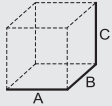
 (A x B x C) mm	VOL./PESO Vol./Weight m ³ /kg	VAC 230V-1N 50Hz (60 Hz optional) kW	POTENZA GAS CAMERA Oven cavity gas power kW	DISTANZA TRA LE TEGLIE Distance between the layers mm	DIM. CAMERA Cavity net dimension mm
519x838x770 6 GN 1/1	0,5 / 96	1,3	5,5	30	380x540x370

ACCESSORIES

- Stand TK1
- Racks for stand TK1 cod. 2023000
- Stand for stacking TK21
- Probe for sous-vide cooking 6000115
- Hand spray 7080003

- A Electrical connection
- B Softened water inlet (G3/4)
- C Equipotential bonding
- D Drain (Ø40)
- D Humidity discharge (Ø40)
- E Detergent and rinse agent hose inlet
- F Smoke exhaust (Ø40)
- H Gas inlet 1/2"

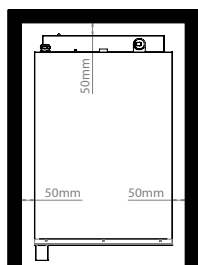

* Clearance requirements

WATER QUALITY REQUIREMENTS

Hardness 60-100 ppm
 TDS <100 mg/L
 PH Value 7.0-8.0
 Cl₂ Free chlorine..... <0,5 mg/L
 Cl Chloride..... <20 mg/L
 Alkalinity..... <20 mg/L
 SiO₂ Silica..... <10 mg/L

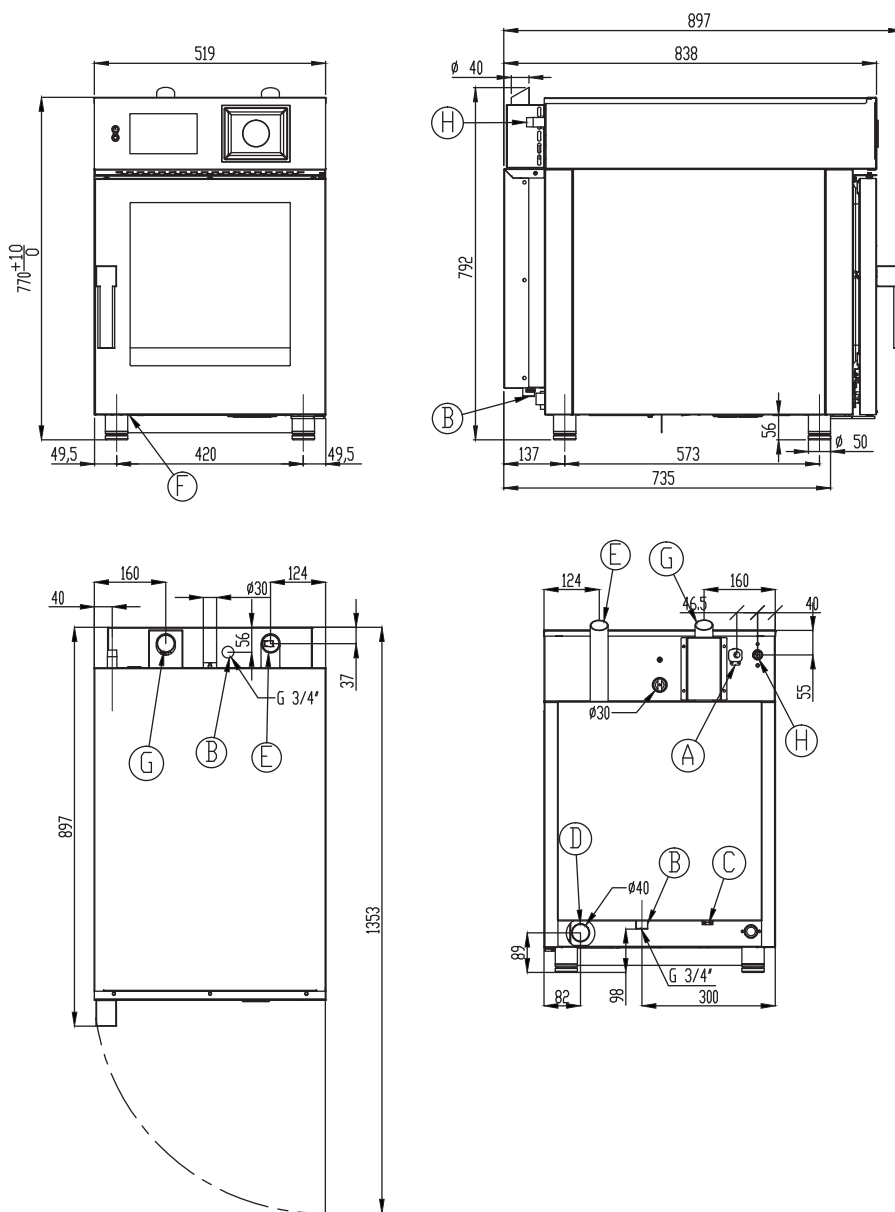

NOTE

* Drain line must be vented