



### TECHNICAL FEATURES

- Heating of cooking chamber with PREMIX GAS BURNERS.
- Rapid chamber ventilation system.
- Meteo system (patented) for humidity control in the cooking chamber.
- Inverter-controlled fan with 6 different speeds.
- Immediate shutdown of the fan rotation by opening the door.
- Steam production with Symbiotic System (patented).
- High efficiency boiler with automatic descaling
- Steam tuner (patented) for tuning dry-wet steam.
- USB port for uploading and saving recipes and for firmware updating.
- Double-glazed ventilated door (panels can be opened for easy cleaning).
- Cooking chamber lighting with LED.
- Height adjustable feet.
- Single control by means of just one jog/dial encoder knob.
- Motorised vent valve opening.

### STANDARD EQUIPMENT:

- Core Probe 6000124
- Automatic washing system (tabs or liquid) - n.4 programs

### OPTIONS:

- Left hinged door (on request)

### USER INTERFACE:

#### TOUCH SCREEN PANEL 7"

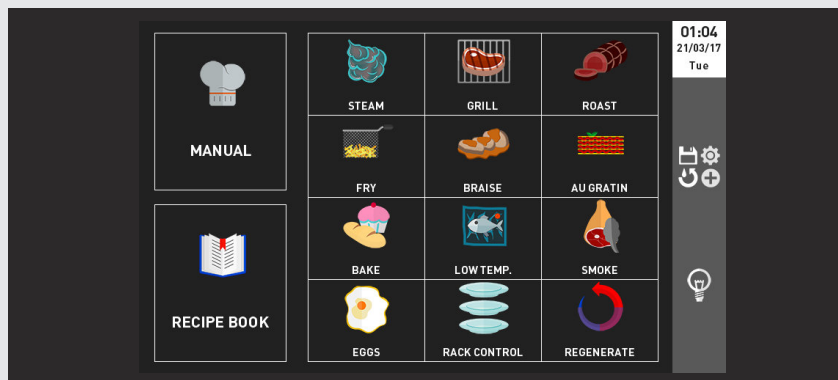

- Temperature control from 50° to 300°C.
- Time control from 1'to599'; infinite function.
- Cooking modes: convection, steam, combi convection/steam.
- Preset cooking programmes. Possibility of controlling 9 cooking phases for each programme.
- Delta T cooking.
- Cooking with probe.
- Multi level cooking with "Rack Control & Easy service".
- Recipe Tuner
- Cooking chamber humidity control (Meteo system).
- Steam tuner: dry-wet steam.
- Cooldown during cooking.
- Dedicated Hot/Cold Smoking programs
- Regeneration function.
- Hot/Cold Smoking cooking mode
- Cooking by Message
- Overnight cooking
- Delayed start

### Meteo SYSTEM

To guarantee a perfectly balanced climate inside the cooking chamber, Giorik has patented a unique humidity control system (Meteo System) using software that analyses the relevant parameters in the cooking chamber and then regulates the production of steam or discharges excess humidity.

### RecipeTuner

The RecipeTuner interface makes it possible to modify and personalise the various programmes simply and intuitively. RecipeTuner changes according to the type of cooking set, to regulate cooking, browning, degree of humidity and of leavening.

### EasyService

level control cooking

The new Rack Control enables different dishes to be cooked at the same time at various levels. What's more, with EasyService, a new Rack Control function, all the dishes can be served at the same time.

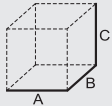
 (A x B x C) mm	<b>VOL./PESO</b> Vol./Weight  m <sup>3</sup> /kg	<b>VAC</b> 230V-1N 50Hz (60 Hz optional)  kW	<b>POTENZA GAS CAMERA</b> Oven cavity gas power  kW	<b>DISTANZA TRA LE TEGLIE</b> Distance between the layers  mm	<b>DIM. CAMERA</b> Cavity net dimension  mm
519x838x1010 <b>10 GN 1/1</b>	0,63 / 118	0,6	11	30	380x540x610

## ACCESSORIES

- Stand TK1
- Racks for stand TK1 cod. 2023000
- Probe for sous-vide cooking 6000115
- Hand spray 7080003

- A Electrical connection
- B Softened water inlet (G3/4)
- C Equipotential bonding
- D Drain (Ø40)
- D Humidity discharge (Ø40)
- E Detergent and rinse agent hose inlet
- F Smoke exhaust (Ø40)
- H Gas inlet 1/2"

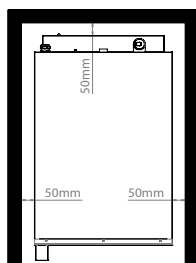

\* Clearance requirements

## WATER QUALITY REQUIREMENTS

Hardness ..... 60-100 ppm  
TDS ..... <100 mg/L  
PH Value ..... 7.0-8.0  
Cl<sub>2</sub> Free chlorine..... <0,5 mg/L  
Cl Chloride..... <20 mg/L  
Alkalinity..... <20 mg/L  
SiO<sub>2</sub> Silica..... <10 mg/L

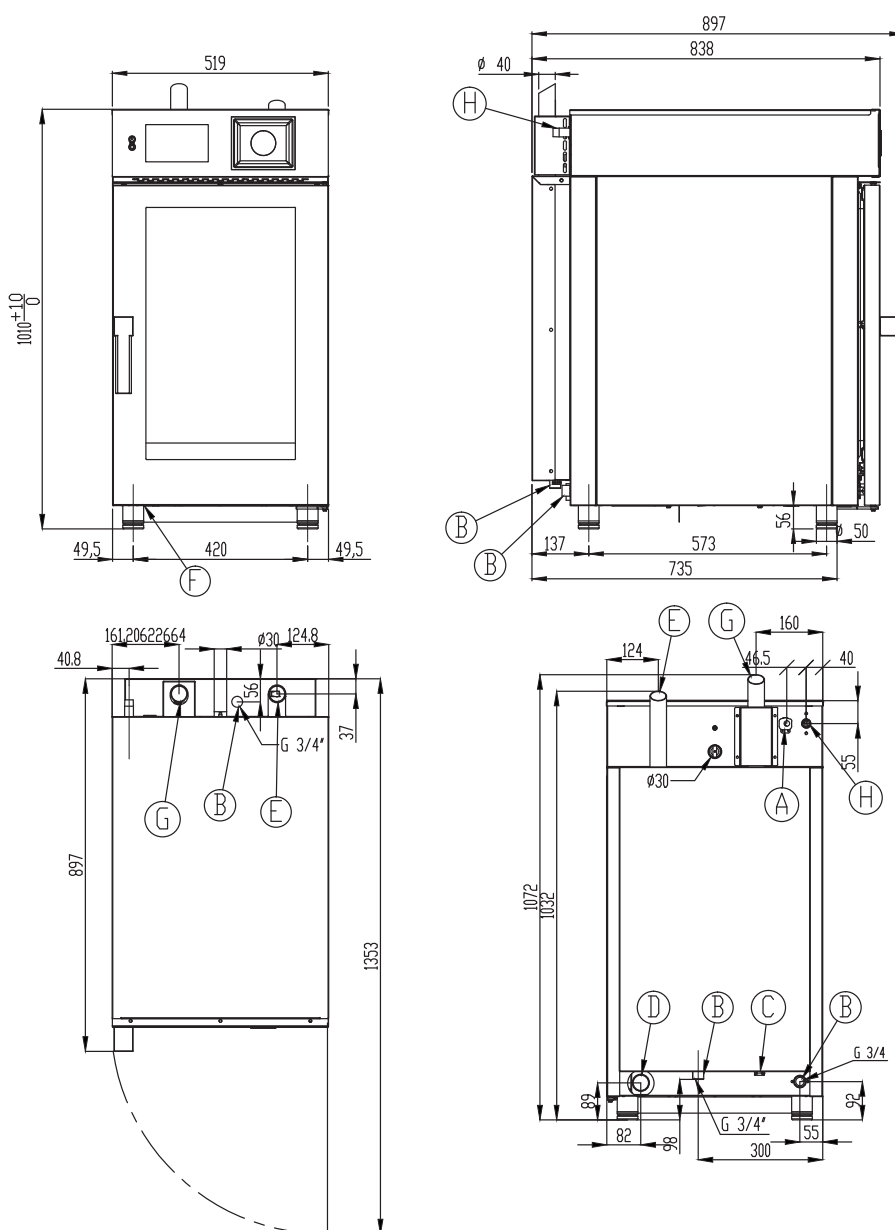

## NOTE

\* Drain line must be vented

**Giorik SpA**

via Cavalieri di Vittorio Veneto, 14  
32036 Sedico (BL) - ITALY

tel. +39.0437.807200

fax +39.0437.807001

e-mail: [info@giorik.com](mailto:info@giorik.com)